

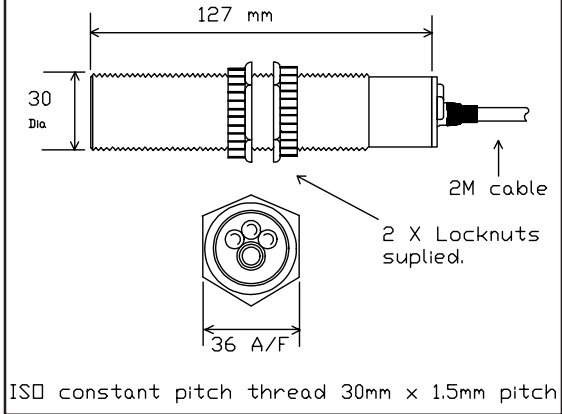

GENERAL SPECIFICATION

- Supply** 12 to 240V dc or 24 to 240V ac.
- Current Consumption** 30 mA maximum.
- Ambient Temp.** -10°C to +50°C.
- Sensitivity** Max detection range=25mm.
- Output** 1 set, Volt free change over relay contacts. Rated at 3 Amps 240V ac max. Non-inductive.
- Sensing Distance** 25mm Max.
- Calibration** Potentiometer. Bin to be empty when calibrating.
- Indication** 2 colour L.E.D indicates presence or absence of material and timer function sequence. L.E.D flashes when timer is operable.
- Cable** 2 metres, 5 core.
- Enclosure** Moulded Polycarbonate.
Threaded 30mm x 1.5mm.
- Protection** IP65.
- Timer** Programmable 0 to 10 seconds or 0 to 1 minute.

DIMENSIONS



Guarantee

The equipment is covered by a 12 months guarantee from the date of shipment. Any faults arising due to faulty materials or workmanship, within the guarantee period, will be corrected free of charge providing the equipment is returned to us carriage paid.

Certificate of Conformity

The equipment covered by these instructions has been manufactured and tested in accordance with our quality assurance procedures and conforms fully with our published specification.

Health and Safety

Provided that the equipment covered by these instructions is installed and operated as directed, it presents no hazard and conforms fully to health and safety regulations.



THIS PRODUCT CONFORMS TO THE REQUIREMENTS FOR CE MARKING

When this product is incorporated into other machinery or apparatus, that apparatus must not then be put into service (in the E.C) until it has been declared in conformity with the appropriate E.C Directive/s.



Walsall Road, Norton Canes, Cannock, Staffs. England.

644-012K

->UC1TRMAN

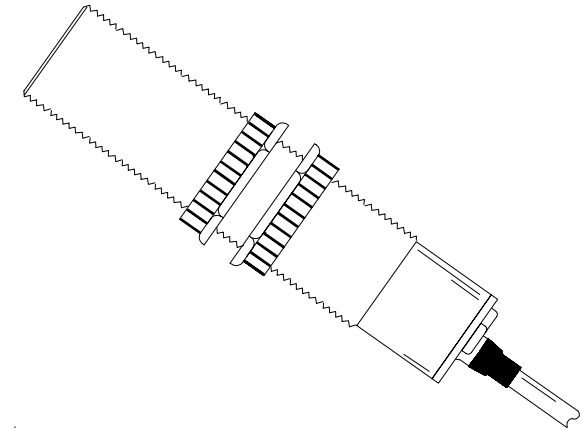

PROGRAMMABLE CAPACITANCE SENSOR TYPE UC1TR

OPERATING INSTRUCTIONS





INTRODUCTION

The UC1TR is a programmable capacitance sensor which detects the presence or absence of liquids and bulk granular materials, i.e. grain, feeds, seeds and chemicals etc.

The UC1TR is multivoltage, 12 to 240V dc or 24 to 240V ac, and is supplied with a two colour L.E.D. and two controls. The L.E.D. indicates the presence or absence of material, and the time delay sequence, as material arrives and leaves. Controls are provided to set the operating range (sensitivity) and time delay.

INSTALLATION

The UC1TR may be mounted horizontally or vertically. Mount the sensor into the container, using nuts provided or a suitable M30 x 1.5 fitting. In metal containers, the sensor must protrude at least 20mm beyond metalwork. Alternatively the sensor will operate from the outside of most non metallic vessels (max 6mm thickness) or through a non metallic plate on metal types. Ensure that there is at least 20mm clearance from the sensor to the nearest metalwork.

Ensure that the connections to the UC1TR are correct. Check that there is no material around tip of sensor.

UC1TR Timer/Programming Control: Carefully turn both controls (range and timer) fully anti-clockwise. Note: Total movement of the sensitivity/range control is 4 full turns. To prevent damage the screw adjuster

CONNECTIONS

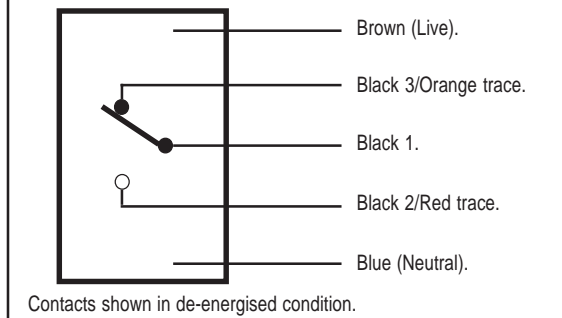

continues to rotate after 4 turns. The timer control is a single turn potentiometer. Do not use excessive force otherwise damage may occur. Check that the green L.E.D is illuminated. If the operating sequence requires changing, proceed as detailed under 'Program mode'. Note: The unit must be installed before calibration takes place.

With no material around the sensor, rotate the range control clockwise until L.E.D changes to red. Slowly rotate anti-clockwise until L.E.D changes to green. Optimum setting is then usually obtained by rotating the control a further 10° anticlockwise. The desired time range can be set by rotating the timer control clockwise to increase time. Note: The L.E.D flashes during timing sequence under normal operation.

SEQUENCE OF OPERATION

Material Flow	L.E.D Status
Material detected (after delay)	Red LED
Material absent (after delay)	Green LED
Time delay after material arrives	Flashing Red LED*
Time delay after material leaves	Flashing Green LED*

**(Flashing LED's only occur if time delays have been programmed)*

FACTORY PROGRAMME SETTING

The unit is factory preset as follows:
0-1 Min timer, Delay on make & break and relay energised with material absent.

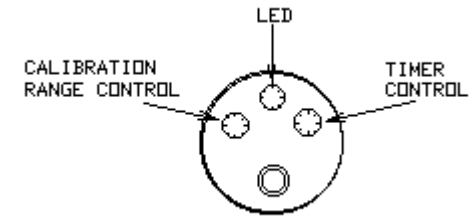

(Layout of controls on rear of UC1TR)

Alternative features can be selected by programming the unit as detailed below:-

Program mode: Rotate time control fully clockwise, apply power and rotate time control fully anti-clockwise before the L.E.D changes from red to green. (This takes approximately 3 to 4 seconds).

The unit will step from red to green 5 or 6 times at 0.5 second intervals. At each transition to green a separate function may be selected (see below) by altering the time control from fully anti-clockwise to fully clockwise, or leaving it in the anti-clockwise position.

