

Guarantee

The equipment is covered by a 12 months guarantee from the date of shipment. Any faults arising due to faulty materials or workmanship, within the guarantee period, will be corrected free of charge providing the equipment is returned to us carriage paid.

Certificate of Conformity

The equipment covered by these instructions has been manufactured and tested in accordance with our quality assurance procedures and conforms fully with our published specifications.

Health and Safety

Provided that the equipment covered by these instructions is installed and operated as directed, it presents no hazard and conforms fully to health and safety regulations.

CE

THIS PRODUCT CONFORMS TO THE REQUIREMENTS FOR CE MARKING

When this product is incorporated into other machinery or apparatus, that apparatus must not then be put into service (in the E.C) until it has been declared in conformity with the appropriate E.C Directive/s.

SYNATEL

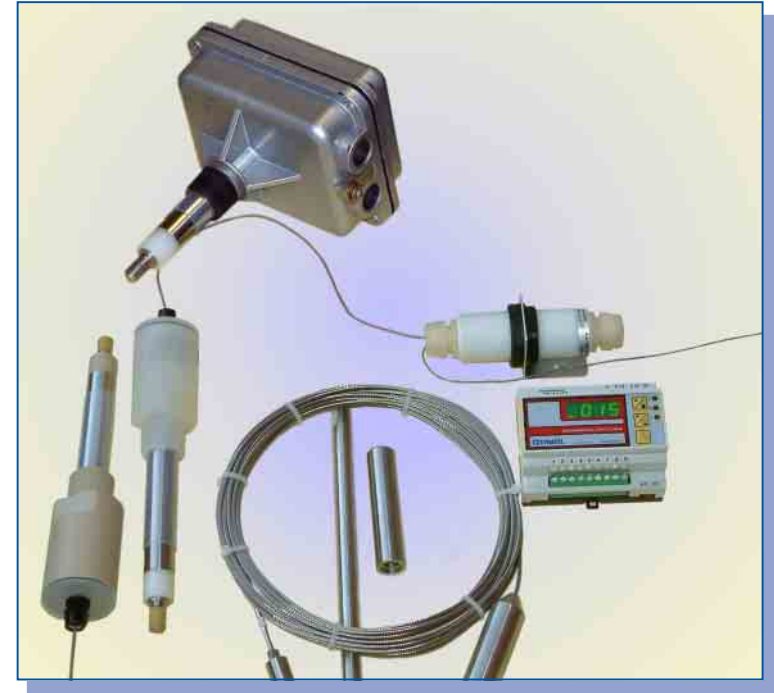

DMR2A

CAPACITANCE LEVEL PROBE SYSTEM

Manual No: M2484

SYNATEL

Cannock, Staffordshire. WS11 9TB UK

Tel: +44 (0) 1543 277003

Fax: +44 (0) 1543 271217

web: www.synatel.co.uk

e-mail: sales@synatel.co.uk

642-042(A)

>: DMR2Aman

OPERATING INSTRUCTIONS

ATEX ✓
Approved

SPECIAL CONDITIONS FOR SAFE USE

*The following probe system consists of a control module (DRC205A) with either a self contained probe head with transponder node circuit (RNY**), or a junction box with node circuit (DCT2AE), or in-line junction box with node circuit (DCT2*). The junction boxes are generally used with remote probes (typically) RPP1 or RPK1. In all variations, the instructions shown below MUST be followed, where applicable:*

- 1) The DRC205A control unit SHALL be mounted in a safe area only.
- 2) The DCT2A tubular enclosure is suitable for use only where there is a low impact risk, unless fitted into a stainless steel or plated steel 'L' shaped bracket that is a maximum of 1mm thick and approximately 50mm wide.
- 3) The DCT2A and DCT2T tubular enclosures SHALL be protected from UV exposure.
- 4) The end user MUST ensure that permanently wired and suitably clamped cable is used at ALL times
- 5) The enclosures SHALL be fitted with suitable ATEX apparatus certified cable glands and/or stopping plugs. Component stopping plugs SHALL be Hawke type 375 or 378.
- 6) ALL Pflitsch glands & CEAG M16 glands are ONLY suitable for low risk use.
- 7) The RNY**, DCT2AE and DCT2* enclosures SHALL not be used under dust layers exceeding 50mm.

RNY** Digimatic housing with internal node circuit

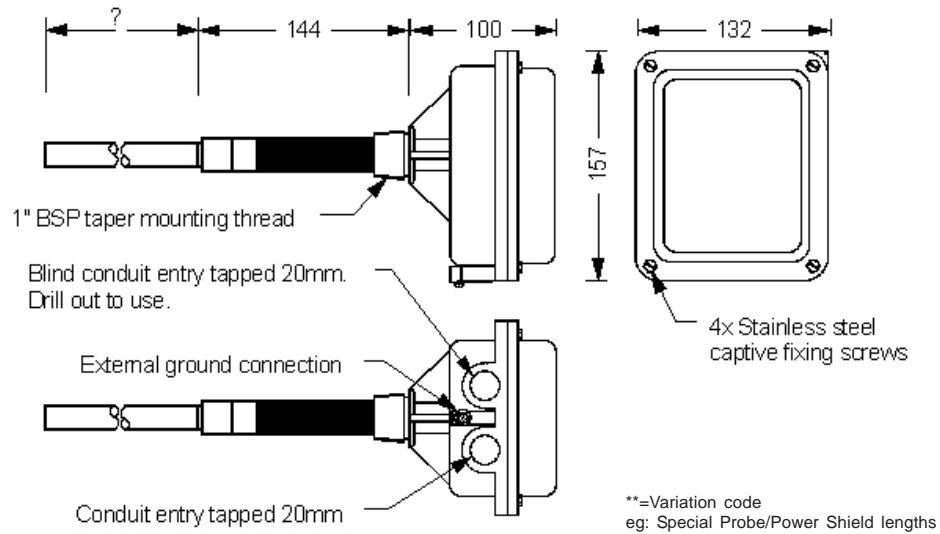

INTRODUCTION

The DIGIMATIC DMR2A level control system is a fixed point system comprising a remotely mounted control unit (DIN rail mountable), transponder node and probe assembly. The transponder node must be mounted locally to the probe and a wide range of probe assemblies are available to suit different applications, some variations include the transponder circuitry within the probe head.

The control unit may be mounted upto 100 metres from the transponder and incorporates all controls and indicators (see figs 2, 3 & 4). A four digit 7 segment display is provided to show process variables and aid calibration.

Calibration can be automatic, manual or a combination of both.

INSTALLATION

Probes with rods supplied separately include a thread locking compound. Both halves of the thread must be kept clean and free from grease, oil and dirt. Probe length may be altered prior to assembly.

Fit the probe rod hand tight. The compound will lock in about 20 minutes and gain full strength after 24 hours.

ONCE HARDENED, THE ROD CANNOT BE REMOVED.

Install probe into the container making sure that the power shield (when fitted) is protruding sufficiently into the container (see fig 1).

Typical Probe Head Arrangement - showing power shield mounting.

fig1

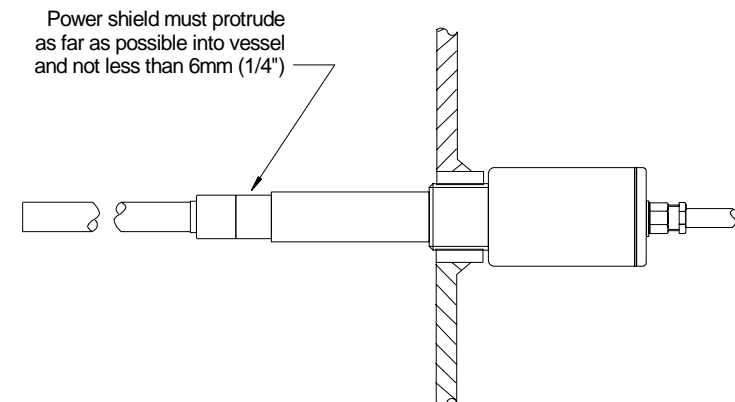

Install the DRC205A control unit within a suitable enclosure or control panel. Fit the transponder node circuit within 0.5 metres of the probe (where used).

Notes:-

a) The system sensitivity is proportional to the surface area of the probe. When using a 16mm dia. probe the minimum length to use, for the majority of materials, is 200mm. This should be treated as the minimum surface area if possible.

If the probe length needs to be reduced to less than 200mm, the surface area should be maintained. This can be achieved by increasing the diameter, by fitting a metal tube over the probe, or by bending the probe rod. A 100mm x 2.2 dia probe is available. In certain high density materials it may be possible to reduce the length without compensation.

b) We offer a free product test service. To use this service, supply 2 litres of product in a sealed container (to prevent ingress or loss of moisture), the product will be tested and its suitability confirmed. You should also notify us of any safety precautions which should be observed during testing.
(Supply appropriate COSHH datasheet).

CONNECTIONS

The DRC205A will operate on 110V/230V ac 50/60Hz supplies. Power connections to the unit may be wired in ordinary un-screened cable of any length and need not be separated from other cables. Connections between control unit and transponder node must be made in 2 core screened cable up to 100 metres long. Where the transponder node is mounted separately from the probe it is supplied with 500mm of high temperature cable. **This must not be extended.**

Connect in accordance with fig 2, 3 or 4 depending upon system being used. Set fail safe switch to required position (see fig 5), and ensure that all cable glands and covers are fully tightened when finished. The unit should be wired and grounded in accordance with appropriate Electrical and ATEX Regulations.

A supply ground earth is essential on terminal 10 of the DRC205A. A local ground must also be connected to metalwork as near to the probe as possible. Metal flanges used to fit probes in non-metallic bins must also be bonded to the same point.

STANDARD CONNECTIONS

fig 2

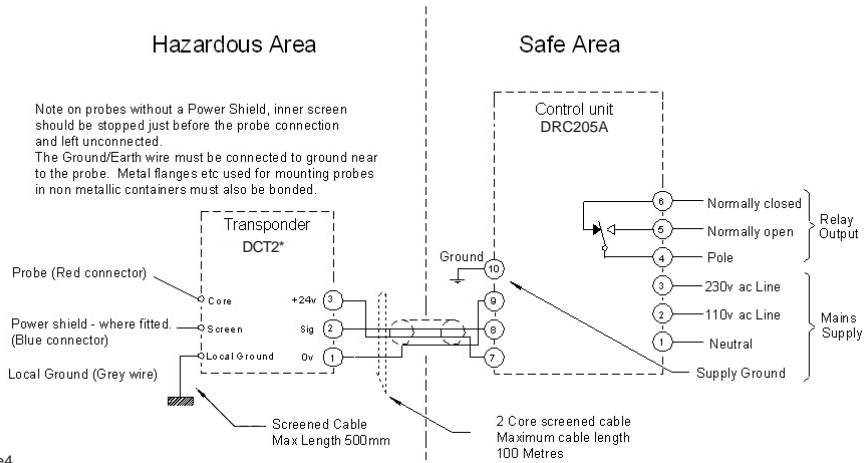

DIMENSIONS

DRC205A Module

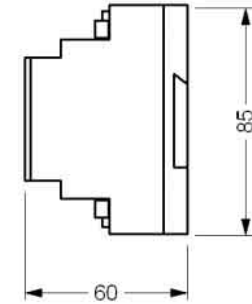
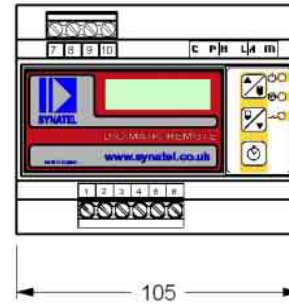

DCT2AE Transponder Module

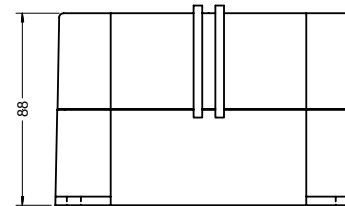
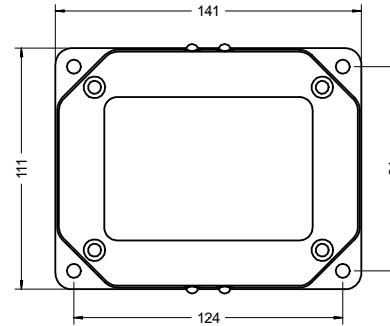

DCT2* In-line Junction Box with node circuit

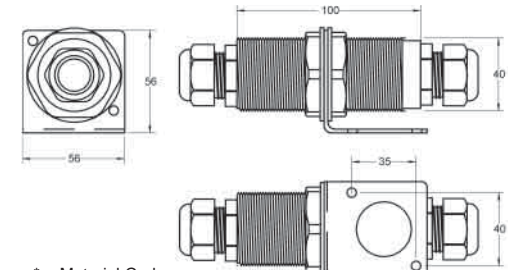

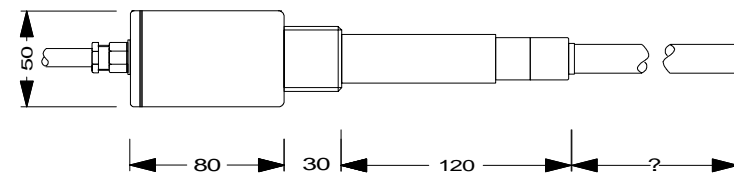

* = Material Code:
A = Acetal, P = Polycarbonate, N = Nylon, T = Teflon
i.e: for DCT2 with Acetal body (stock machined unit), order DCT2A

RPP1 (polypropylene) or RPK1 (peek) Typical Probe Assembly



TIME DELAY

The DRC205A has an adjustable delay from 0 to 127 seconds, the timer operating on both material arriving and leaving. To set the time delay, proceed as follows.

- 10) Set the Cal/Park switch to Cal.
- 11) Press and hold the  button. The display will show t000 and increment in 1 second steps. Release the button when the required delay time is shown.
- 12) Return the Cal/Park switch to Park and press  to confirm the timer setting.
- 13) The timer can be altered to a longer or shorter delay by repeating the procedure from 10) above.

| SPECIFICATION | |
|---|--|
| DMR2A Overall Specification/Approval | |
| DRC205A Control Unit | Part of Baseefa05ATEX0119X (Ex II 1D) [Ex iaD 20] 2W 110/230V. For safe area installation only! |
| Protection: Enclosure: Mounting: Voltage: Rating: Operating Temperature: Output: Time Delay: | IP44. Moulded. Din Rail. 110/230V ac 50/60 Hz (+7½%-15%). 2W. -15°C to +50°C. S. P. C. O. Contacts rated at 2.5A 240V ac Non-inductive. 0-127 seconds variable. Set via membrane keypad. Delay applies when material arrives and leaves the probe. |
| Max. distance between control unit and probe assembly: | 100 metres in 2 core screened cable. |
| Probe Assembly Type (Typical) | |
| Temperature: Protection: Material: Earth Bonding: Probe Length: Mounting: | (RPP1) Polypropylene up to 120°C; (RPK1) Peek up to 250°C. IP65. Polypropylene & Stainless steel (RPP1) or Peek & Stainless steel (RPK1). Earth connection must be bonded adjacent to metalwork of container. 100mm, 200mm, 1 metre, 2 metre or 10 metre wire rope. (Stainless steel). 1" BSP parallel male. |
| Transponder DCT2* | Baseefa05ATEX0119X 1W 27V (Ex II 1D Ex ID A20 (Ex iaD) 20 T125°C. Tamb -15°C to +50°C |
| Protection: Operating Temperature: Power Supply: Cable Glands: Connections: | IP66. -15 to +50°C Derived from DRC205A Cable glands supplied for connections to probe and DRC205A Terminals provided for connection of two core screened cable to DRC205A remote control unit. Max 100 metres. 0.5 metre high temperature screened cable prefitted for connection to probe (must not be extended) . |
| Transponder DCT2AE | Baseefa05ATEX0119X 1W 27V (Ex II 1D Ex ID A20 (Ex iaD) 20 T125°C. Tamb -20°C to +50°C |
| Protection: Operating Temperature: Power Supply: Cable Glands: Connections: | IP65. -20 to +50°C Derived from DRC205A Cable glands supplied for connections to probe and DRC205A Terminals provided for connection of two core screened cable to DRC205A remote control unit. Max 100 metres. 0.5 metre high temperature screened cable prefitted for connection to probe (must not be extended) . |
| Probe/Transponder RNY** | Baseefa05ATEX0119X 1W 27V (Ex II 1D Ex ID A20 (Ex iaD) 20 T100°C. Tamb -20°C to +50°C |
| Protection: Operating Temperature: Power Supply: Cable Glands: Connections: | IP65. -20°C to +50°C Derived from DRC205A 2 x M20 threaded entries, one blank (drill out only). Use ATEX approved glands. Terminals provided for connection of two core screened cable to DRC205A remote control unit. Max 100 metres. |
| Earth Bonding: Probe Length: Mounting: | Earth connection must be bonded adjacent to metalwork of container. 100mm, 200mm, 1 metre, 2 metre or 10 metre wire rope. (Stainless steel). 1" BSP parallel male. |

* & ** = unit variations

OTHER VARIATIONS CONNECTIONS

fig 3

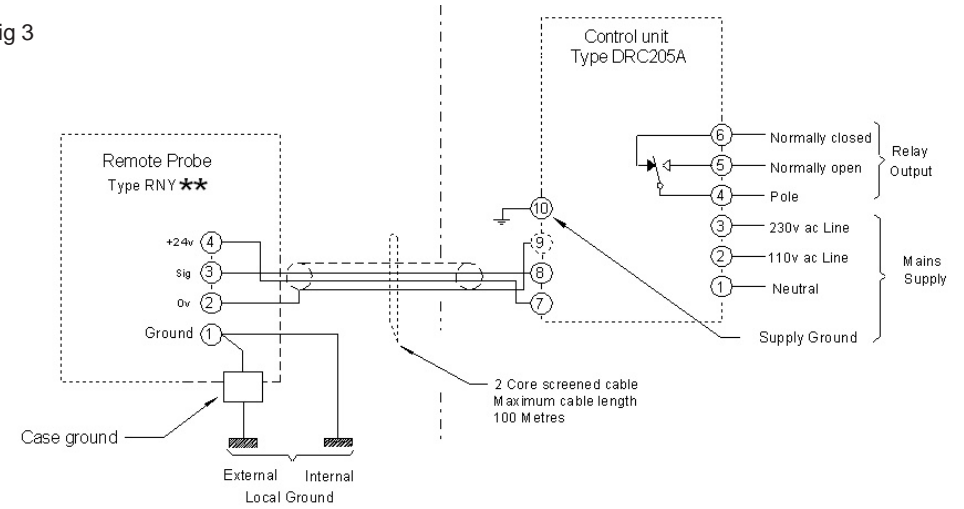
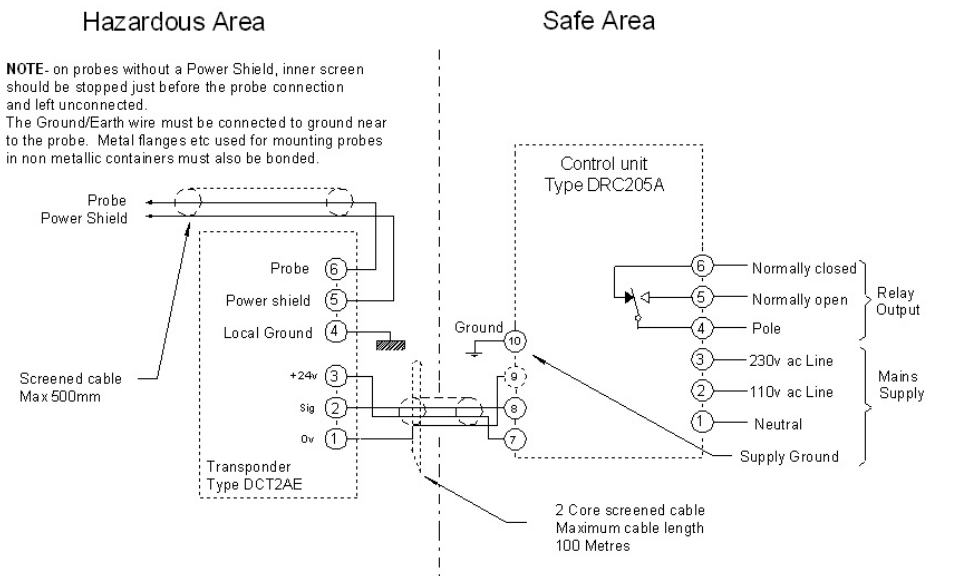

fig 4



SWITCH SETTINGS (fig5)

Cal/Park: Set to 'Park' for normal operation. Set to 'Cal' to allow calibration or timer setting.

High/Low: sets the fail safe mode. In the "High" position, the relay is de-energised with material present. In the "Low" position, the relay is energised with material present. Normally, the "High" position is used for high level probes and the "Low" for low level probes. Intermediate probe settings depend upon individual requirements.

Auto/Man: Set to 'A' for automatic calibration, or 'M' for manual calibration.

fig 5

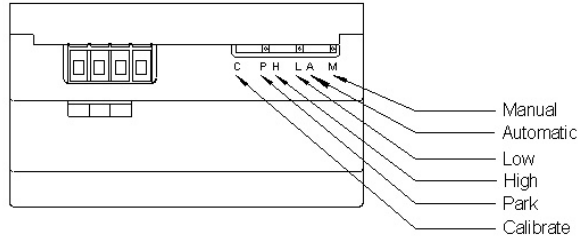

COMMISSIONING

The DRC205A can be calibrated automatically, manually or by a combination of the two methods. Usually, automatic calibration is the simplest method, particularly when the vessel can be filled to cover the probe.

Manual calibration is useful when a number of probes in similar applications need to be set. Once the correct calibration has been determined and noted, on one system, the remainder can be set to the same setting.

DISPLAY FUNCTIONS (fig 6)

The display shows a number of different values depending upon whether the unit is in manual or auto mode, and cal or park mode.

fig 6

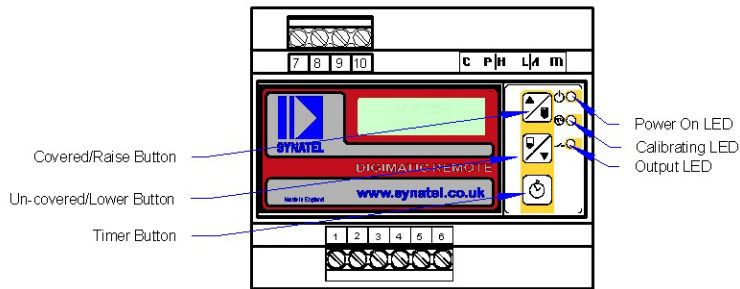

Park Mode

In normal operation the display shows a value representing the capacitance measured by the probe at the time.

Pressing the button will cause the display to show uxxx followed by rxxx. Pressing the button will cause the display to show cxxx followed by rxxx. cxxx is the probe covered value measured during calibration, uxxx is the uncovered value and rxxx is the relay operating point which the Digimatic calculates and is half way between the two measured values.

Note: The settings are "view only" in park mode, they cannot be altered.

Cal Mode - auto/man switch set to auto, Cal/Park switch set to Cal

In this mode, pressing the button with the probe uncovered will cause the unit to measure and display the uncovered value and recalibrate the relay operating point if necessary. Pressing the button with the probe covered will cause the unit to measure and display the covered value, again recalibrating the relay operating point if necessary.

Cal Mode - auto/man switch set to man, Cal/Park switch set to Cal

In this mode, pressing the button will cause the display to momentarily display the present relay operating point and then to increment the setting slowly and then rapidly to set a higher operating point. Pressing the button will cause the display to momentarily show the current relay operating point, and then decrement the setting, slowly and then rapidly.

Once adjusted in manual mode, any previous settings will be lost. The cxxx reading will be 1 above the relay operating point and the uxxx reading 1 below.

Note: Always return to "Park" (after calibration)

CALIBRATION

Semi Automatic Calibration - material available

- 1) Set Park/Cal switch to Cal and Auto/Man switch to Auto. The Cal LED will flash.
- 2) Ensure that the probe is uncovered and press and hold the button. The display will show uxxx followed by rxxx.
- 3) Fill the vessel sufficiently to cover the probe and then press the button. Display will show cxxx followed by rxxx.
- 4) Return the Park/Cal switch to park. The unit is now calibrated. uxxx & cxxx values can be viewed but not altered by pressing the & buttons.

Semi Automatic Calibration - material not available

- 5) Follow steps 1 & 2 above.
- 6) Set Cal/Park switch to Park and press the button. Note the uxxx reading but ignore the rxxx reading. Return the Cal/Park switch to Cal and set the Auto/Man switch to Man.
- 7) From the table below, select the nearest material to the type to be detected and add the value to the uxxx reading determined in (6).
- 8) Press the button to raise the reading and the button to lower the reading to achieve the setting calculated in 7.
- 9) Return the Cal/Park switch to Park and press the & buttons to confirm that the relay operating point rxxx is correctly set. The uxxx & cxxx settings will be one below and one above the readings.

Table of Typical Settings

| Material Type | Increment |
|---------------|----------------|
| Light | +15 |
| Medium | +30 |
| Heavy | +60 or greater |